

Power Assist[®] Boxes

Operation and Maintenance Guide

Models: PA07-AD, PA10-AD, PA12-AD

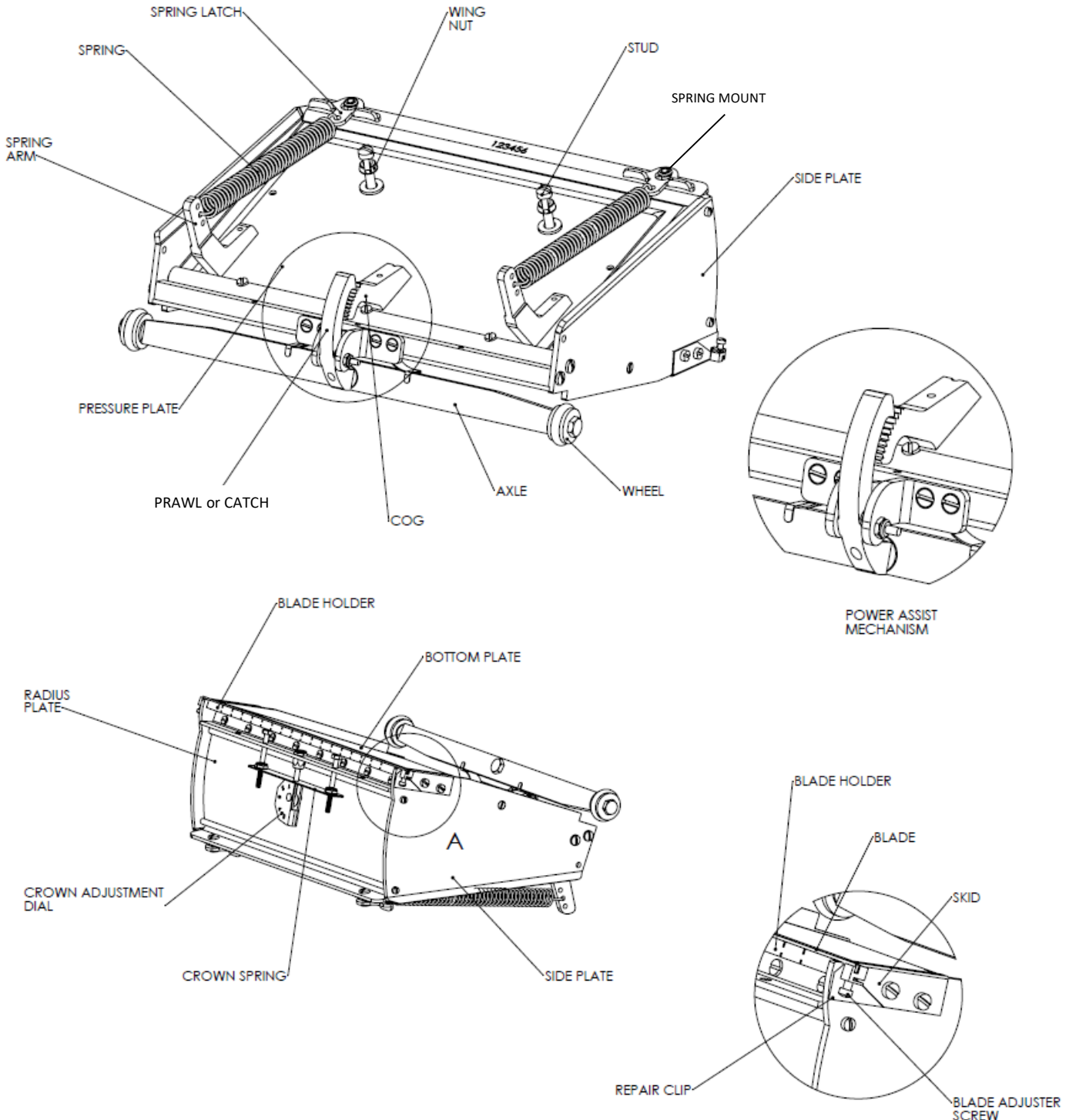

Models: PA07-AD, PA10-AD, PA12-AD

Operation

The Power Assist[®] Box applies joint compound over taped joints. This style of finishing box requires 50% less effort to operate compared to standard finishing boxes and produces uniform results every time. It comes in three widths, generally used for finishing as follows:

- 7" (175 mm): applies bed coat
- 10" (250 mm): applies bed coat or finish coat
- 12" (300 mm): applies finish coat or skim coat

The Power Assist[®] Box is controlled by the finishing box handle. Finishing box handles are available in different lengths, including extendable versions. The handle is attached to the finishing box by sliding the box onto the flange of the handle and tightening the two wing nuts.

Notice the spring arms mounted on the pressure plate of the Power Assist box. These arms are connecting points for the power assist springs. The other end of the springs is attached to the top of the radius plate by stretching them over and onto the spring mounts. Pull the pressure plate out to the fully open position. Note that the pressure plate will "catch" in that position and be held there. There is a "lock" mounted on the left side of the pressure plate that holds the tool in the fill position. Fill the box with joint compound through the opening behind the blade using the slot adapter and Loading Pump.

The finishing box wheels activate the power assist mechanism. This is done by pressing the box against the wall in such a way that the axle is compressed and the "prawl" or "catch" releases the cog on the pressure plate. The joint compound will not flow until this "catch" is released. As soon as the catch releases, compound will start slowly flowing from the box. **It is standard practice with the Power Assist finishing box to place the blade of the box on the surface first and then press the wheels against the surface.**

Once you press the wheels against the surface to release the catch, move the box along the joint to be finished. You will need to apply very little pressure to keep the joint compound flowing from the box. The amount of pressure needed will vary with conditions and compound consistency. Note, if you have trouble getting the "catch" to release, try placing the box on the wall, wheels first.

The metal blade trowels the compound with the precise crown needed. This is set using the crown adjustment dial. This dial controls the amount of crown left on the joint with #1 being the most amount of crown (more joint compound applied) and #5 the least (less joint compound applied).

To position the finishing box on the joint to be covered, lock the finishing box at a slight angle (approximately 30%) by squeezing the brake grip on the handle with one hand. Your other hand should grip the handle near the box.

Press the blade of the box on the surface, then release the brake grip and press the wheels against the surface simultaneously, beginning to move the finishing box along the joint. Approximately two-thirds of the way along the joint, squeeze the brake grip again and sweep the finishing box off the surface. It is suggested that you begin to sweep the wheels off the wall about 6" (150 mm) before the intended stopping point to keep excess compound from flowing onto the outside of the box.

Reverse hand positions and start at the opposite end of the joint from where you began. Repeat the process of placing the finishing box on the surface and sweep off when you overlap the first pass of joint compound. This procedure is followed for all ceiling joints and horizontal wall joints.

Models: PA07-AD, PA10-AD, PA12-AD

Operation (continued)

To cover vertical wall joints, lock the handle and begin covering the joint from the bottom up to a height of about 30" (.75 m), sweep off and begin again at the top of the joint. Move down the joint until you reach the previous stopping point. Then lock the handle and sweep off the surface, neatly joining the two finished sections.

For door or window openings, always work from the corner, moving toward the opening. Just before the wheels reach the opening, lock the handle and lift the wheels to keep them from dropping into the opening, then sweep away from the wall.

Before starting the finish coat, lightly sand the dried topping coat to remove any small crumbs. Fill the 10" or 12" (250-300 mm) box and set the dial to #3 for a medium crown. Apply a finish coat to all joints. For butt joints, apply a coat on either side of the center of the joint. After the two side by side coats have dried, finish them with a 10" or 12" (250-300mm) wide skim coat over the center of the joint.

Reset the crown dial to #5 for a tight crown then cover the flat joints on the ceilings and walls.

The pressure plate on the Power Assist® Box CANNOT be moved inward unless the wheels are triggered and the pressure plate "catch" is released. This applies to both running the tool and emptying unused compound. To refill the Power Assist® Box, pull back on the handle to open the pressure plate to its open position.

Maintenance

Remove the springs from the mounts on top of the radius plate to open the pressure plate for cleaning. The wheels must be triggered to re-install the pressure plate into the box after cleaning.

Clean thoroughly with brush and water (or water hose) to remove all joint compound from the tool. Then, after the tool is clean, lightly oil with TapeTech® Bazooka® Oil or any light machine oil.

Finishing Box Blade Replacement

1. To remove the used blade, place the tip of a screwdriver against one end of the blade and tap the screwdriver with the palm of your hand.
2. If the blade does not pop out, tighten the screw at one end of the brass blade holder, forcing the end of the blade out. Back the screw up and again tap the end of the blade.
3. Use one end of the used blade to clean any dried compound from the blade holder slot.
4. Remove both right and left skids, but leave the repair clips in place.
5. Slightly bend the new blade approximately 2 inches from both ends. This will help secure the blade while the tool is in use.
6. Start at one end, pressing the blade all the way into the blade holder, working to the other end. Install new skids. The "dog ear" on the skids should press against the back side of the new blade and be flush with the blade holder (about the thickness of a thumbnail lower than the blade edge).

Common Wear Parts

7" (175mm) Stainless Steel Blade: 200001
10" (250mm) Stainless Steel Blade: 250001
12" (300mm) Stainless Steel Blade: 300001

Skid Cover (Right): 209006
Skid Cover (Left): 209039